

# 感應式高壓油壓缸FA TYPE

## Sensor High Pressure Hydraulic Cylinder

謙泰空油壓

# 感應式高壓油壓缸FA TYPE

## Sensor High Pressure Hydraulic Cylinder

CHIAN TAY HYDRAULICS

- 可加裝感應線在油壓缸上，不佔空間安裝容易  
The attachment of the sensor line takes only a little space of hydraulic cylinder and is very easy for installation.
- 使用壓力140 kg/cm<sup>2</sup> (14MPa)  
Use of pressure: 140 kg/cm<sup>2</sup>
- 感應式油壓缸附加磁性感應活塞搭配磁簧進接開關 可做訊號檢出  
The attachment of magnetic sensor piston and magnetic spring access switch can offer signal inspection functions.

表示方法：

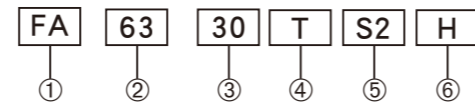

1	固定方式
2	油壓缸內徑(mm)
3	油壓缸行程(mm)
4	活塞桿型式：N內牙、W外牙、T車溝槽、T2銑溝槽
5	感應線2條
6	加電木板，不加電木板H不表示，模具溫度超過80°C以上建議加電木板

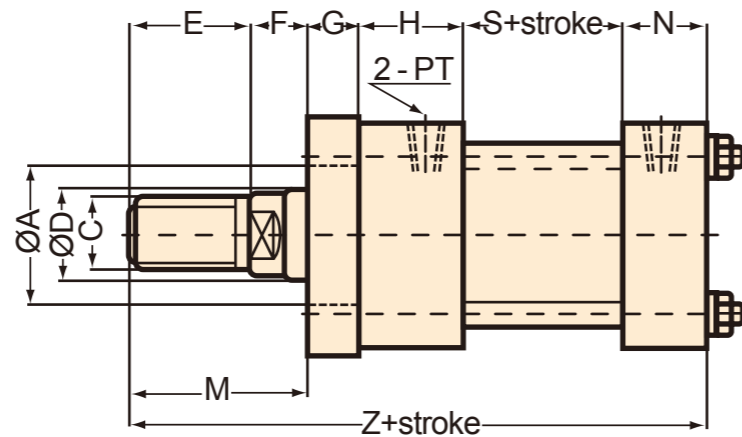
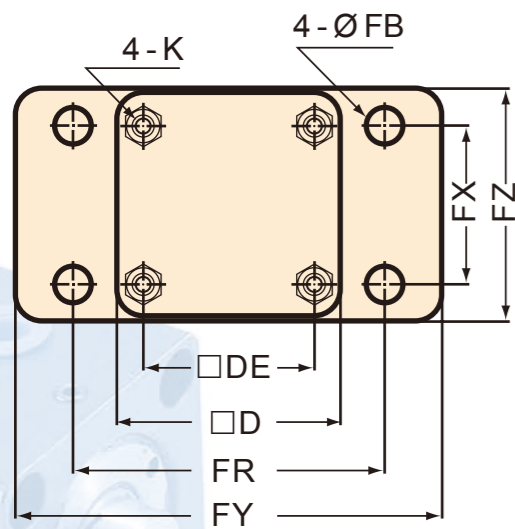

SIZE BORE	Ø A	Ø D	C	D	DE	E	F	G	H	N	M	Ø FB	FR	FX	FY	FZ	K	S	Z	PT
Ø32	30	16/20	M14XP1.5	50	34	28	15	11	27	23	43	9	80	34	105	52	M8XP1.25	50	154	1/4
Ø40	40	25	M22XP1.5	65	45	40	20	17	33	28	60	12	93	50	115	75	M10XP1.25	60	198	3/8
Ø50	45	30	M26XP1.5	80	56	40	20	17	38	30	60	14	110	56	150	85	M12XP1.5	60	208	3/8
Ø63	50	35	M30XP1.5	90	62	45	20	17	38	30	65	14	126	68	155	95	M14XP1.5	60	210	3/8
Ø80	55	40	M30XP1.5	110	80	45	20	20	38	35	65	18	152	75	190	120	M16XP1.5	72	230	1/2
Ø100	65	50	M40XP2.0	131	95	55	25	20	41	37	80	20	180	100	220	140	M18XP1.5	86	264	1/2
Ø125	80	60	M50XP2.0	162	122	70	35	30	57	47	105	24	222	122	280	170	M22XP1.5	98	337	3/4
Ø150	100	80	M70XP2.0	195	144	80	35	30	60	50	115	28	260	155	310	206	1-8UNC	107	362	3/4

銅套

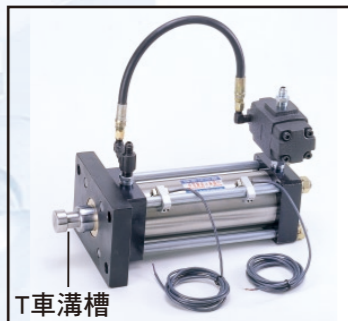

T車溝槽

加裝引導式逆止閥，可保持油壓缸的壓力在射出時不後退。



電木板

模具溫度超過80°C以上，建議模具與油壓缸間加電木板隔離溫度，電木板厚5mm

### 訂購圖

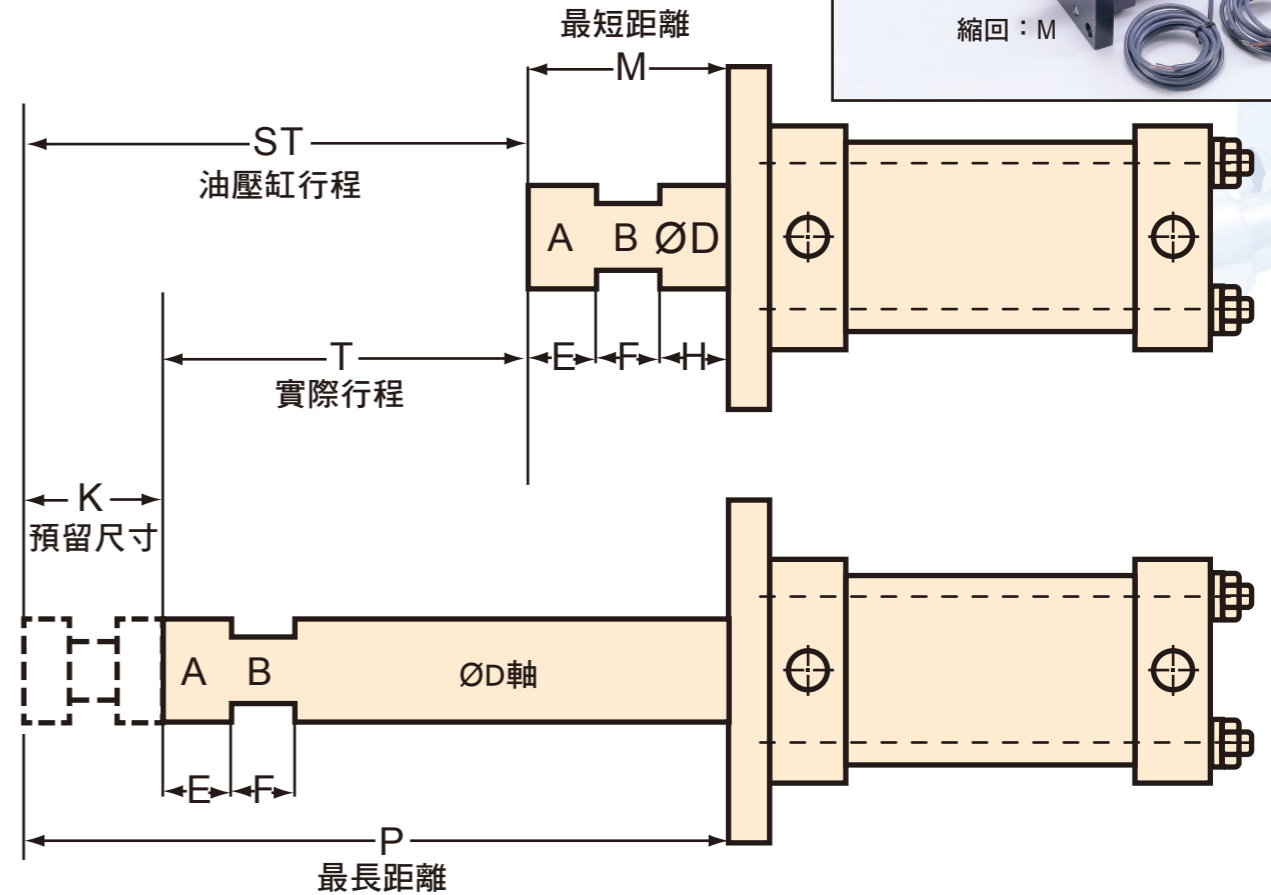
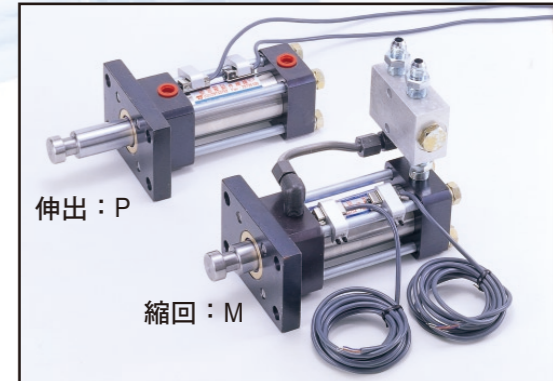

M：最短距離      T：實際行程 Actual stroke      ST：油壓缸行程(T加K)  
P：最長距離      K：預留尺寸 Reserved size      Hydraulic cylinder stroke(T plus K)

A	B	ØD	E	F	H	M	P	T	K	ST	FR	FX	Ø FB

以上空格需填寫圖中應對尺寸

- 建議油壓缸行程50mm以內K值為5-10mm
- 建議油壓缸行程100mm以內K值為10-15mm
- 建議油壓缸行程100mm以上K值為15-20mm

B：銑溝槽比較不會斷裂，A比ØD小2厘米

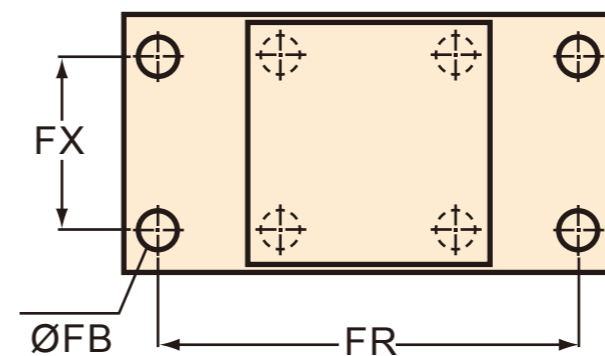

## 謙泰空油壓有限公司

- 地址：台北縣三重市重新路一段42號(台北橋邊)
- TEL: 02-29733752, 29725258, 29735107~8
- FAX: 02-29735109
- E-mail: chian.tay@msa.hinet.net